

# BRAÇOS

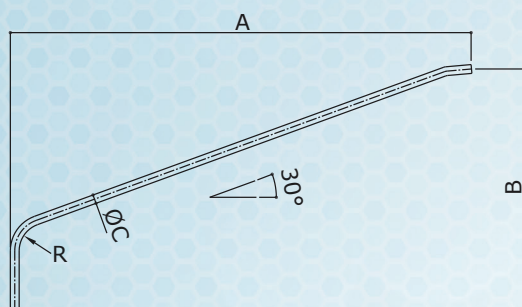

**CJ 10**

BRAÇO CJ - 10				
MODELO	A	B	ØC	K
CJ / 10-10	3140	2275	60,3	30
CJ / 10-20	3820	2650	60,3	25

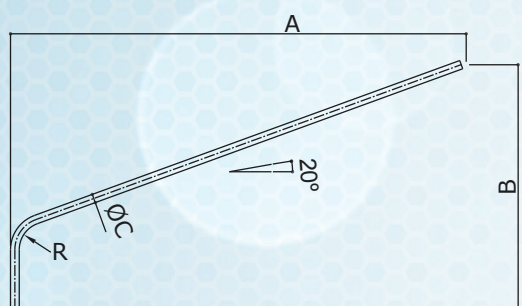

**CJ 20 - 30**

BRAÇO CJ - 20					
MODELO	A	B	R	ØC	K
CJ / 20-10	1000	1120	500	48,2	30
CJ / 20-15	1500	1300	500	48,2	25
CJ / 20-20	2000	1480	500	48,2	20
CJ / 20-25	2500	1660	500	48,2	15

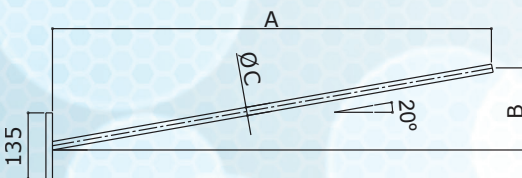

**CJ 40**

BRAÇO CJ - 40				
MODELO	A	B	ØC	K
CJ / 40-10	1000	370	25,4	15
CJ / 40-15	1500	540	25,4	10
CJ / 40-20	2000	700	25,4	5

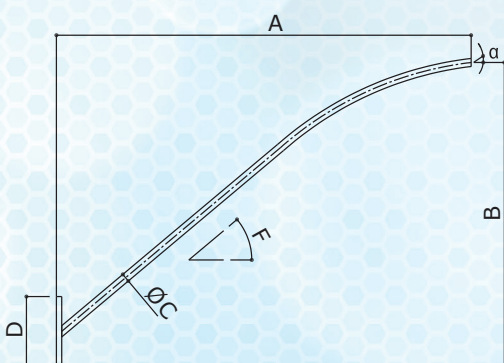

**CJ 50**

BRAÇO CJ - 50							
MODELO	A	B	ØC	D	F	α	K
CJ / 50-33	1991	1650	33,5	260	40°	15°	10
CJ / 50-48	2530	2180	48,2	350	50°	10°	15
CJ / 50-60	2530	2180	60,3	350	50°	10°	25

NOTAS: 1. (K) = peso (kg) máximo da luminária a ser instalada.